

UniLedger

FOR SUPPORTING ROOF AND FLOOR MEMBERS AT AN ANGLE

The MiTek UniLedger has been designed to support floor and roof members at an angle other than 90° to the support.



For durability information, please refer to **Corrosion Resistance of MiTek Metal Connectors**, available on the MiTek website at mitek.com.au

USES

- UniLedgers provide a seat to support floor joists at an angle to floor beams.
- UniLedgers are also used to support hipend trusses in small poly end roofs.
- UniLedgers can be modified and used in a vertical direction for beam to beam connections in situations where other hangers are not suitable.

ADVANTAGES

- Quick and easy to install.

SPECIFICATIONS

Steel Grade	300PLUS
Thickness (Total Coated)	5mm
Coating	Electro or hot dip galvanised
Screws	MSA1430 - MiTek No. 14 x 30mm anti-split self-drilling HD - Qty 4
	10g x 30mm Type 17 bugle head screw - Qty 1
Screws	UL7550

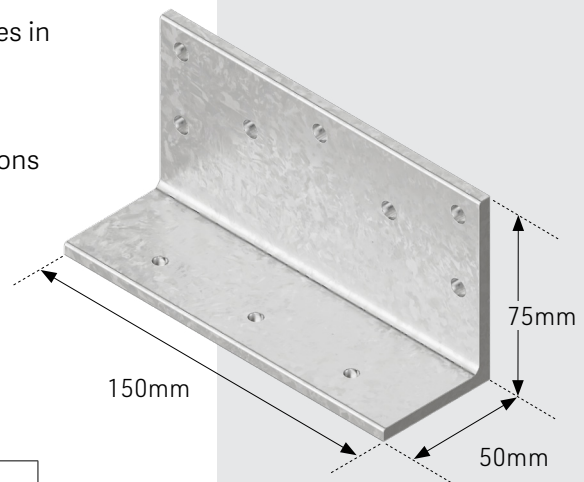

This Certified Engineering Building Product complies with the National Construction Code and Australian Standards.

LOAD DATA

Horizontal Fixing

The total downward capacity of the UniLedger supporting one or more members are shown in Tables 1 and 2 based on the joint group of the supporting member. The maximum uplift wind capacity of each CycloneTie fixing on an incoming truss is 2.25kN. The maximum number of incoming supported trusses is limited to four.

Limit State Design Capacity of UniLedger for Horizontal Fixing with 4 Screws into Supporting Member (kN)											
Table 1	Load Type	Timber Joint Group of Supporting Member									
		J2	J3	J4	J5	J6	JD2	JD3	JD4	JD5	JD6
	DL Only	5.8	4.1	2.9	2.1	1.4	7.3	5.8	4.1	2.9	2.1
	DL + Floor LL	7.0	5.0	3.5	2.6	1.7	8.9	7.0	5.0	3.5	2.6
	DL + Roof LL	7.8	5.6	4.0	2.9	1.9	9.0	7.8	5.6	4.0	2.9
	DL + WL (down)	9.0	8.3	5.9	4.3	2.7	9.0	9.0	8.3	5.9	4.3

Limit State Design Capacity of UniLedger for Horizontal Fixing with 7 Screws into Supporting Member (kN)											
Table 2	Load Type	Timber Joint Group of Supporting Member									
		J2	J3	J4	J5	J6	JD2	JD3	JD4	JD5	JD6
	DL Only	9.0	7.2	5.1	3.7	2.4	9.0	9.0	7.2	5.1	3.7
	DL + Floor LL	9.0	8.7	6.2	4.5	2.9	9.0	9.0	8.7	6.2	4.5
	DL + Roof LL	9.0	9.0	6.9	5.0	3.2	9.0	9.0	9.0	6.9	5.0
	DL + WL (down)	9.0	9.0	9.0	7.5	4.8	9.0	9.0	9.0	9.0	7.5

FIXING CONFIGURATION

Fixing with 4 MiTek screws

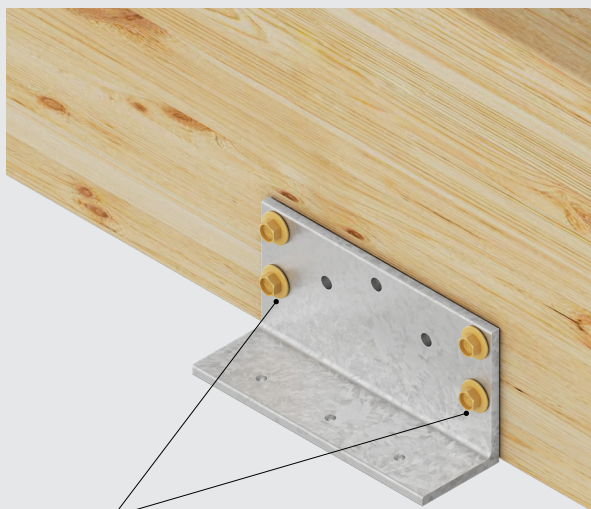

Drive 2 MiTek screws at each end

Fixing with 7 MiTek screws

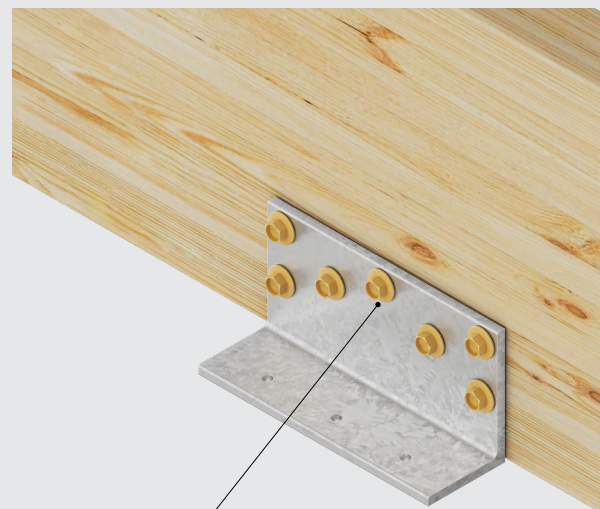

Drive 7 MiTek screws into all holes

INSTALLATION (HORIZONTAL)

Floor Connection

1. Position UniLedger against the supporting beam, waling plate or ledger and fix with either 4 or 7 MiTek MSA1430 screws to obtain the required design capacities in Tables 1 and 2.
2. Place supported member on the UniLedger and fix with one 10 gauge x 30mm Type 17 bugle head screw in the counter-sunk hole provided.
3. Fix one 75 x 3.05mm skew nail to top of supported member.

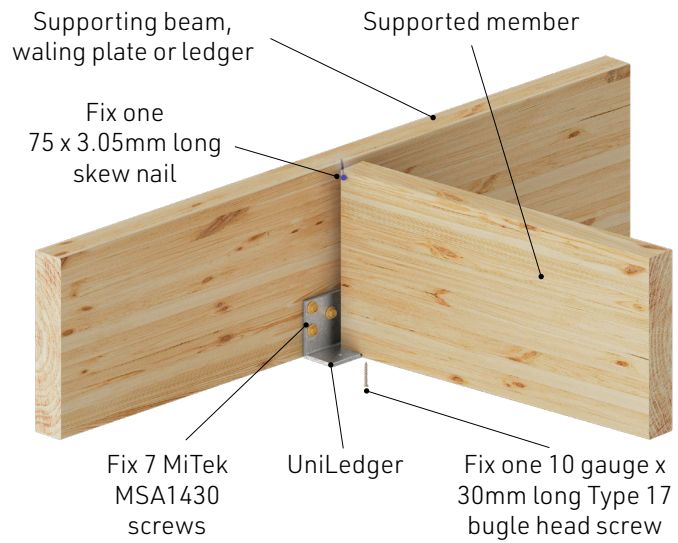

Roof Connection

The UniLedger can support up to four members such as in a poly end roof truss layout.

1. Position the UniLedger against the supporting girder truss and fix with either 4 or 7 MiTek MSA1430 screws to obtain the required design capacities in Tables 1 and 2.
2. Place supported trusses on the UniLedger and fix each truss to girder truss with one CycloneTie CT1200 as shown. The legs of each CycloneTie must be wrapped under the girder truss and fixed to the back of the bottom chord.

Note

Where ceiling is to be fixed directly to bottom chord, notching of supported member to obtain a better ceiling line is acceptable.

Fix 2/30 x 2.8mm MiTek reinforced head nails in each leg to back of girder truss (typical)

CycloneTie CT1200 (typical)

Fix 1/30 x 2.8mm MiTek reinforced head nail to top of bottom chord (typical)

Maximum four supported trusses (double mitred bottom chord required)

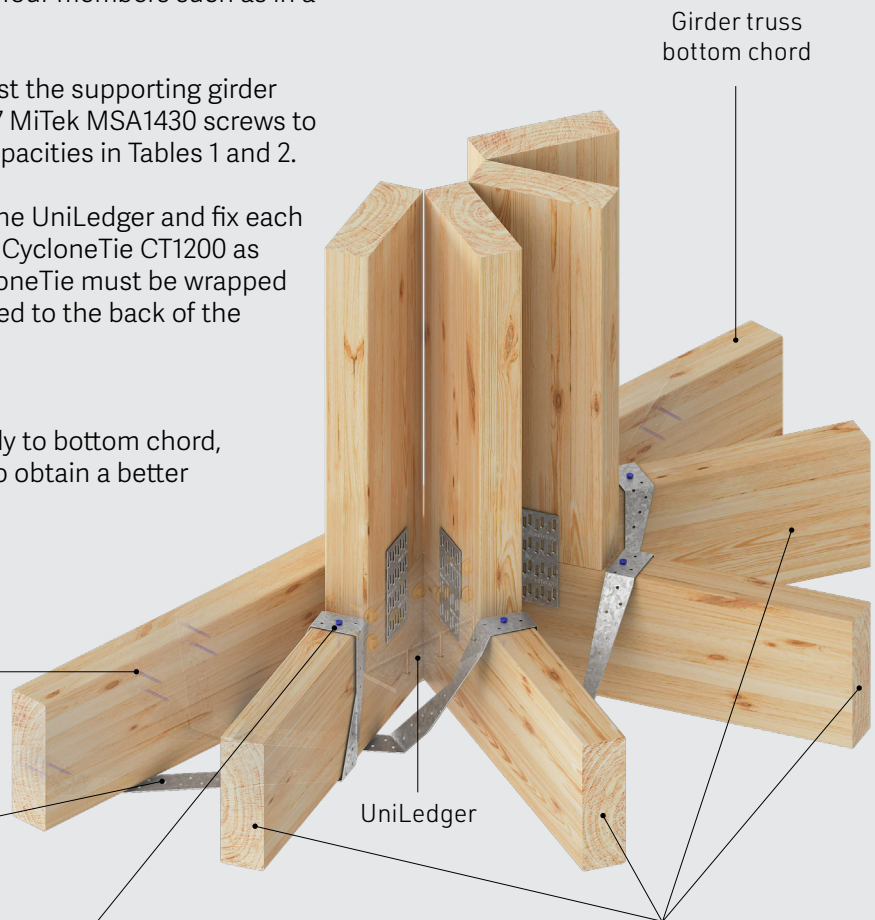

LOAD DATA

Vertical Fixing

When different timbers are used in the support and supported member, select the design capacity base on the weaker joint group in Table 3.

Values in the tables incorporate the Category 1 capacity factor (ϕ) for houses. For other categories, multiply the design capacities by the following factors. Refer to AS1720.1 for a full definition of each category.

Table 3	Limit State Design Capacity of UniLedger for Vertical Fixing with 7 Screws into Each Member (kN)			
	Load Type	Timber Joint Group		
		JD3	JD4	JD5
	DL Only	7.0	5.0	3.5
	DL + Floor LL	8.5	6.0	4.3
	DL + Roof LL	9.5	6.8	4.7
	DL + WL	14.0	10.0	7.1

Category	1	2	3
Adjustment factor	1.00	0.94	0.88

INSTALLATION (VERTICAL)

Product Modification For Vertical Fixing Method

Refer to diagram below, on the shorter leg of the product:

1. Drill additional four 7mm diameter holes with the specified dimensions.
2. Enlarge existing three countersunk holes to 7mm diameter.

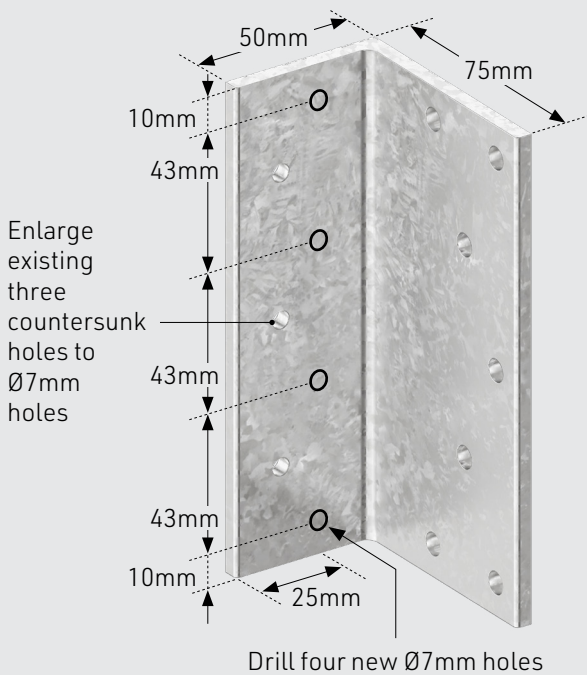

Vertical Connection

UniLedger can be used in a vertical direction for beam to beam connections where other hangers are not suitable.

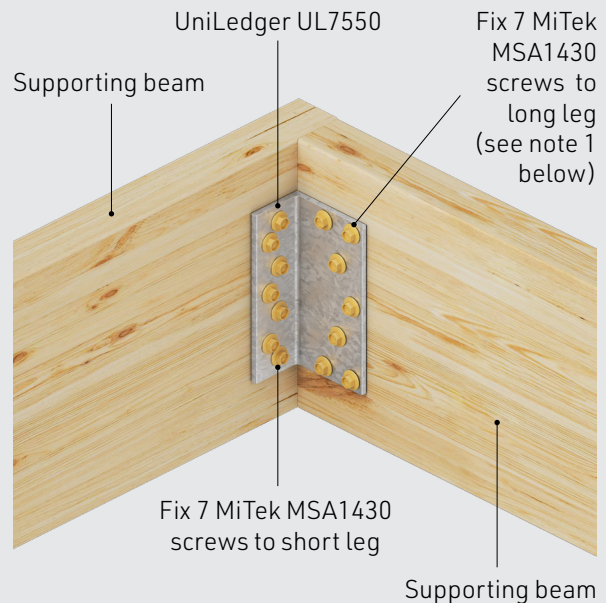

Note

1. Locate long leg of UL7550 against abutting beam to ensure maximum end distance of screws from cut end.
2. Use MSA1465 screws for double beams.

This datasheet is available anytime, anywhere! - Download



EASYCAT
FREE APP

